



Engine	Yanmar 4TNV98T-ZCSLY1/ZCSLY1C
Rated Power	46.3 kW (62 hp / 63 ps) @ 2,200 rpm
Net Power	44.5 kW (60 hp / 61 ps) @ 2,200 rpm
Maximum Dig Depth	4,030 mm
Bucket Capacity	0.32 m ³
Operating Weight	7,500 kg

908E EXCAVATOR

908E SPECIFICATIONS >>>

PERFORMANCE PARAMETERS

Operating Weight	7,500 kg
Std. Bucket Heaped Capacity (Referenced)	0.32 m ³
Maximum Travel Speed	4.8 km/h
Swing Speed	11 rpm
Drawbar Pull	64 kN
Bucket Digging Force (ISO)	56 kN
Arm Digging Force (ISO)	38 kN

ENGINE

Emission Regulation	Tier 3 / Stage IIIA
Manufacturer	Yanmar
Model	4TNV98T-ZCSLY1/ZCSLY1C
Rated Power	46.3 kW (62 hp / 63 ps) @ 2,200 rpm
Net Power	44.5 kW (60 hp / 61 ps) @ 2,200 rpm
Peak Torque	245 N·m @ 1,650 rpm
Number of Cylinders	4
Displacement	3.3 L

UNDERCARRIAGE

Number of Shoes per Side	39
Number of Upper Rollers per Side	1
Number of Bottom Rollers per Side	5

DIMENSIONS

A Shipping Length	6,100 mm
B Shipping Height	2,700 mm
C Track Gauge	1,750 mm
D Undercarriage Width	2,200 mm
E Length to Center of Rollers	2,230 mm
F Track Length	2,845 mm
G Overall Width of Upper Structure	2,215 mm
H Tail Swing Radius	1,785 mm
I Counterweight Ground Clearance	760 mm
J Overall Height of Cab	2,700 mm
K Min. Ground Clearance	360 mm

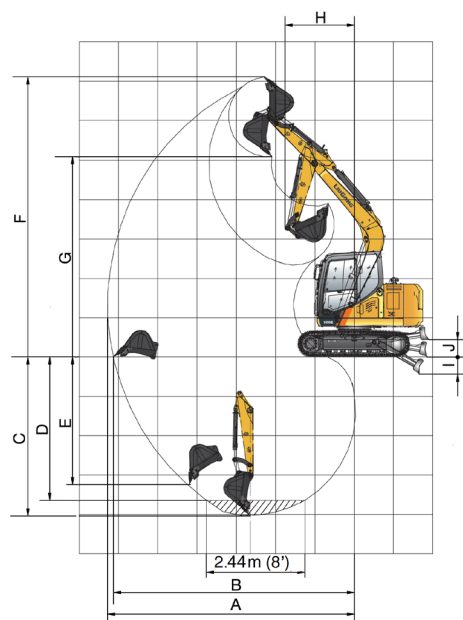
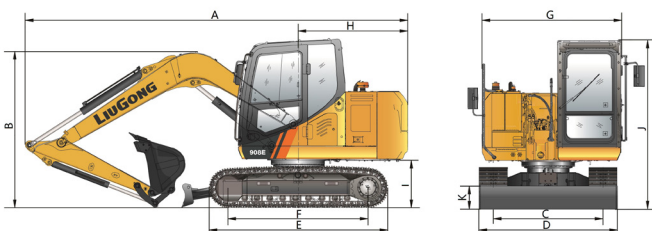

WORKING RANGE

Boom Length	3,710 mm
Arm Length	1,650 mm
A Max. Digging Reach	6,270 mm
B Max. Digging Reach on Ground	6,125 mm
C Max. Digging Depth	4,030 mm
D Max. Digging Depth, 2.5 m (8') level	3,645 mm
E Max. Vertical Wall Digging Depth	3,240 mm
F Max. Cutting Height	7,115 mm
G Max. Dumping Height	5,080 mm
H Min. Front Swing Radius	1,785 mm
I Depth below Ground	440 mm
J Lift above Ground	425 mm

HYDRAULIC SYSTEM

Main Pumps Total Flow	167.2 L/min
Relief Pressure, main	29.4 MPa

SERVICE CAPACITIES

Fuel Tank	140 L
Engine Oil	11.6 L
Cooling System	12 L
Hydraulic Reservoir	80 L
Hydraulic System Total	110 L

Guangxi Liugong Machinery Co., Ltd.

No. 1 Liutai Road, Liuzhou, Guangxi 545007, PR China
 T: +86 772 3886124 E: overseas@liugong.com
 www.liugong.com

Specifications and designs are subject to change without notice. Machines shown may include optional equipment. Liugong standard and optional equipment may vary from region to region. Please consult your Liugong dealer for information specific to your area. Engine power kW is converted to horsepower (1 kW=1.3596 ps and 1 kW=1.3410 hp) in this file.

05/2022 Designed by LiuGong
 Replace the previous versions of 09/2021